

FORMING TAP

BURR-BIT®

PIPE TAP

BURR-BIT®

Burr-Bits designed for forming taps!

- Burr-Bit models specifically designed to fit oil/vent grooves of forming taps.
- Tap and deburr in one operation. More production—less downtime.
- Eliminates material drawn up above the surface by forming taps.
- Deburrs the top of the tapped hole as the tap is being withdrawn.
- Burr removal eliminates sharp edges—providing a smooth surface for mating components.
- 120° cutter angle standard (82°, 90°, 100°, etc. are available upon request).
- Tap and Burr-Bit can both be supplied for a perfect fit. No need to shop for tap fit—we guarantee these!
- For forming tap brands that are manufactured to fit Burr-Bits, contact Vernon.

Burr-Bits for PipeTaps!

- Burr-Bits specifically designed for NPT and NPS pipe taps are stocked for immediate delivery in sizes from 1/8" to 1".
- Highly recommended where a clean chamfer-to-thread transition is required for pipe fitting assemblies.
- Larger models are available by special order.

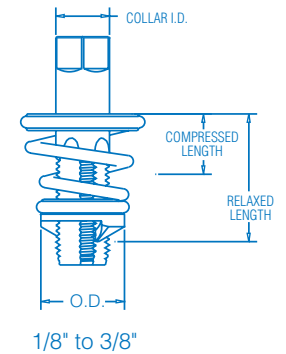
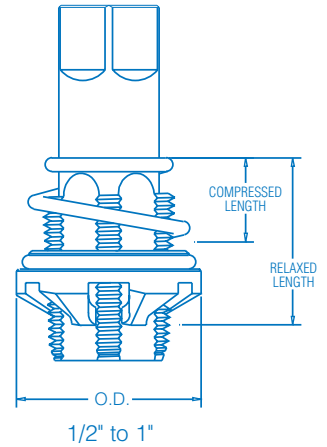
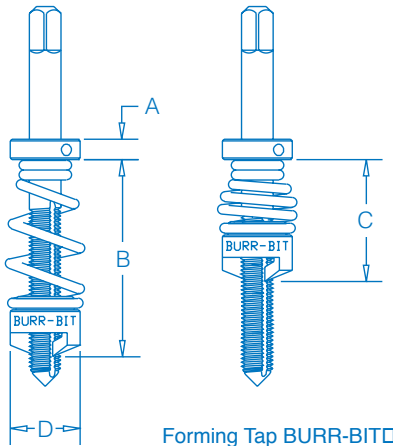

BURR-BITS FOR FORMING TAPS

(Fractional, Machine Screw and Metric)

Part#	Tap Size	Part # (Metric)	Tap Size	A (in)	B (in)	C (in)	D (in)
20410	#4	--	--	11/64	7/8	45/64	3/8
20510	#5	30310	M3	11/64	55/64	23/32	3/8
20610	#6	--	--	11/64	55/64	23/32	3/8
20710	#8	30320	M3.5	11/64	7/8	45/64	3/8
--	--	30410	M4	11/64	7/8	45/64	3/8
20810	#10	30510	M5	11/64	1- 1/16	25/32	3/8
20910	#12	--	--	11/64	1- 1/16	25/32	3/8
21110	1/4	30610	M6	11/64	1- 9/64	7/8	1/2
21210	5/16	30810	M8	11/64	1- 1/4	61/64	9/16
21310	3/8	31010	M10	11/64	1- 1/4	61/64	21/32
21410	7/16	31210	M12	11/64	1-27/32	1-11/32	13/16
21510	1/2	--	--	11/64	1-47/64	1-15/64	13/16

BURR-BITS FOR PIPE TAPS

NPT/NPS

Part#	Style	Collar ID (in)	Cutting Lips	O.D. (in)	Relaxed Length (in)	Compressed Length (in)
041101	1/8-2PT	.312	2	21/32	1-1/16	5/8
041107	1/8-5PT	.312	5	21/32	1-1/16	5/8
041100*	1/8-2PT	.437	2	21/32	1-1/16	5/8
041106	1/8-5PT	.437	5	21/32	1-1/16	5/8
041200*	1/4-2PT	.562	2	13/16	1-5/16	3/4
041203	1/4-5PT	.562	5	13/16	1-5/16	3/4
041300*	3/8-4PT	.700	4	1- 1/8	1-5/16	7/8
041302	3/8-5PT	.700	5	1- 1/8	1-5/16	7/8
041400*	1/2-4PT	NONE	4	1- 1/2	1-3/8	7/8
041402	1/2-5PT	NONE	5	1- 1/2	1-3/8	7/8
041500*	3/4-5PT	NONE	5	1- 1/2	1-1/2	7/8
041502	3/4-4PT	NONE	4	1- 1/2	1-1/2	7/8
041600*	1-5PT	NONE	5	1- 7/8	1-7/8	1-1/8

* Indicates most common items