

SPOT-BIT® / SINK-BIT®

VERNON DEVICES, INC.
914 • 633 • 0038
fAX 914 • 633 • 0059
WWW.VERNONDEVICES.COM

Combination Drill and Countersinking or Drill and Spot-facing Tools.

- Drill and countersink, or drill and spot face, in one operation!
- Highly recommended where counter sinking and spot facing must be perfectly aligned with drilled holes.
- Rigid tool holder and cutter heads encase nearly the entire drill for outstanding support.
- Positive stop screw in the shank provides drill length adjustment.
- Dual set-screws in the cutter head provide secure support and driving force.
- Robust cutter heads can be sharpened repeatedly and are easily replaced.
- Sink-Bits are available from 1/8" to 21/32" and 3mm to 16.5mm, with countersink angles of 82° or 90°. Other angles available on special order.
- Spot-Bits are available from 1/8" to 21/32" and 3mm to 16.5mm, and can counter-bore to approximately 1/8" deep.
- Sink-bits can be made available at special angles other than 82° or 90°.
- Spot-Bit cutter diameters can be altered to meet specific needs.



SPOT-BIT PART NO. / DIMENSIONAL DATA

(Fractional, No., Letter and Metric Sizes)

Part#	Drill Size Range	Part# (Metric)	Drill Size Range	A (in)	B (in)	C (in)	D (in)
CSPH-	.1250-.1660	CSPM-	M3-M4	1/2	5/8	3-3/16	1/2
CSPH-	.1690-.2050	CSPM-	M4.5-M5	1/2	5/8	3-9/16	1/2
CSPH-	.2090-.2812	CSPM-	M5.5-M7	13/16	15/16	4	3/4
CSPH-	.2900-.3480	CSPM-	M7.5-M9	13/16	15/16	4-1/2	3/4
CSPH-	.3580-.4530	CSPM-	M9.5-M11.5	1-1/8	1-5/16	5-1/8	7/8
CSPH-	.4680-.5460	CSPM-	M12-M14	1-1/8	1-5/16	6-1/8	7/8
CSPH-	.5620-.6560	CSPM-	M14.5-M16.5	1-1/2	1-5/8	6-5/8	1

NOTE: All complete tool part numbers are preceded by CSPH-____ or CSPM-____, followed by the drill diameter (eg. CSPH-2500 = 1/4" Spot-Bit). For replacement cutter head only, omit the prefix "C".

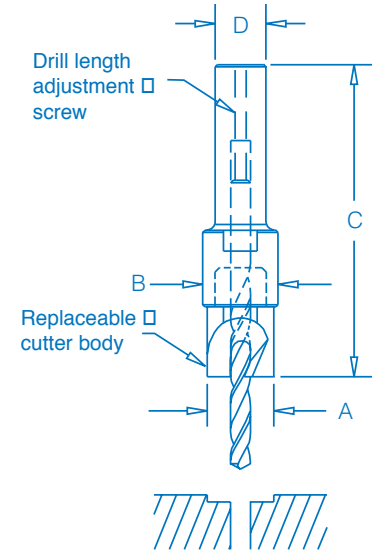

SINK-BIT PART NO. / DIMENSIONAL DATA

(Fractional, No., Letter and Metric Sizes)

Part# (82°)	Part (90°)	Drill Size Range	Part# (82°) (Metric)	Part# (90°) (Metric)	Drill Size Range	A (in)	B (in)	C (in)	D (in)
CSKH82-	CSKH90-	.1250-.1660	CSKM82-	CSKM90-	M3-M4	1/2	5/8	3-3/16	1/2
CSKH82-	CSKH90-	.1690-.2050	CSKM82-	CSKM90-	M4.5-M5	1/2	5/8	3-9/16	1/2
CSKH82-	CSKH90-	.2090-.2812	CSKM82-	CSKM90-	M5.5-M7	13/16	15/16	4	3/4
CSKH82-	CSKH90-	.2900-.3480	CSKM82-	CSKM90-	M7.5-M9	13/16	15/16	4-1/2	3/4
CSKH82-	CSKH90-	.3580-.4530	CSKM82-	CSKM90-	M9.5-M11.5	1-1/8	1-5/16	5-1/8	7/8
CSKH82-	CSKH90-	.4680-.5460	CSKM82-	CSKM90-	M12-M14	1-1/8	1-5/16	6-1/8	7/8
CSKH82-	CSKH90-	.5620-.6560	CSKM82-	CSKM90-	M14.5-M16.5	1-1/2	1-5/8	6-5/8	1

NOTE: All complete tool part numbers are preceded by CSKH82-, CSKH90-, or CSKM82 & CSKM90, followed by the drill diameter (eg. CSKH90-2500 = 90° 1/4" Sink-Bit). For replacement cutter head only, omit the prefix "C".

