

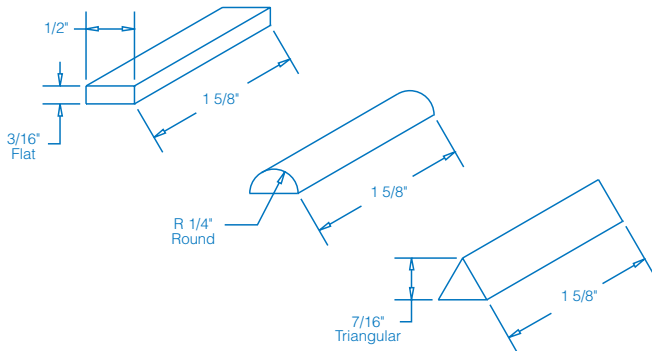

For hand touch-up of Tungsten Carbide and high speed steel cutting tools.

- Next to diamond in hardness, yet less expensive than diamond hones and lasts far longer.
- Sintered boron carbide grains are suspended in a tough matrix which resists grain pull-out and premature separation.
- Outstanding performance lasts for years!
- Shapes and removes metal rapidly and cleanly.
- Four grits from 240 to 600.
- Best for touch-up of T/C and HSS tools already set up in machine tools. No need to disturb setup.
- One of the few honing tools you can really bear down on.
- Choice of flat, semicircular or triangular shaped stone allows development of complex profiles.
- Cemented onto sturdy 7" long handle with a 2X magnifier.
- Glaze is easily cleaned off with an ordinary pencil eraser.



GRIT-BIT

Part #	Use	Grain Size	Shape
GB240	ROUGHER	240	FLAT
GB320	HONER	320	FLAT
GB400	LAPPER	400	FLAT
GB600	ULTRA	600	FLAT
RGB240	ROUGHER	240	ROUNDED
RGB320	HONER	320	ROUNDED
RGB400	LAPPER	400	ROUNDED
RGB600	ULTRA	600	ROUNDED
TGB240	ROUGHER	240	TRIANGLE
TGB320	HONER	320	TRIANGLE
TGB400	LAPPER	400	TRIANGLE
TGB600	ULTRA	600	TRIANGLE

Boron Carbide WHEEL-BIT®

- Wheel-Bit is a sintered Boron Carbide dressing stick. It's more cost effect than and next to diamond in hardness. Unsurpassed in wear resistance.
- Recommended for all grinding wheels. Cuts cleanly, shears through abrasive particles without plucking grains from the binder.
- Clean and shape grinding wheels in just a couple of passes. Reface grinding wheels in minutes. Touch-up cup or saucer wheels.
- Form a profile, radius or groove quickly and easily.
- Thoroughly dresses grinding wheels without glazing.



WHEEL-BIT

Part #	Item	Dimensions
WB100	Wheel-Bit	1/4" x 1/2" x 3"